

256C

Skid Steer Loader



Features

The Cat® 256C Skid Steer Loader, with its radial lift design, delivers excellent digging performance with outstanding drawbar power.

The 256C features the following:

Sealed and Pressurized Cab. Provides a cleaner and quieter operating environment.

Seat Mounted Adjustable Joystick Controls and available Air Ride Seat. These features make the C-Series the industry leader in operator comfort.

High Performance Power Train. Provides high engine horsepower and torque. Electronic Torque Management and standard foot throttle allow the machine to be operated at part throttle for lower sound levels and fuel consumption.

High Flow XPS Hydraulic System. Available for applications that demand maximum hydraulic work tool performance.

Serviceability. Easy routine maintenance helps reduce machine downtime for greater productivity.

Work Tools. Caterpillar's broad range of performance matched work tools make the Cat Skid Steer Loader the most versatile machine on the jobsite.

CATERPILLAR®

256C Specifications

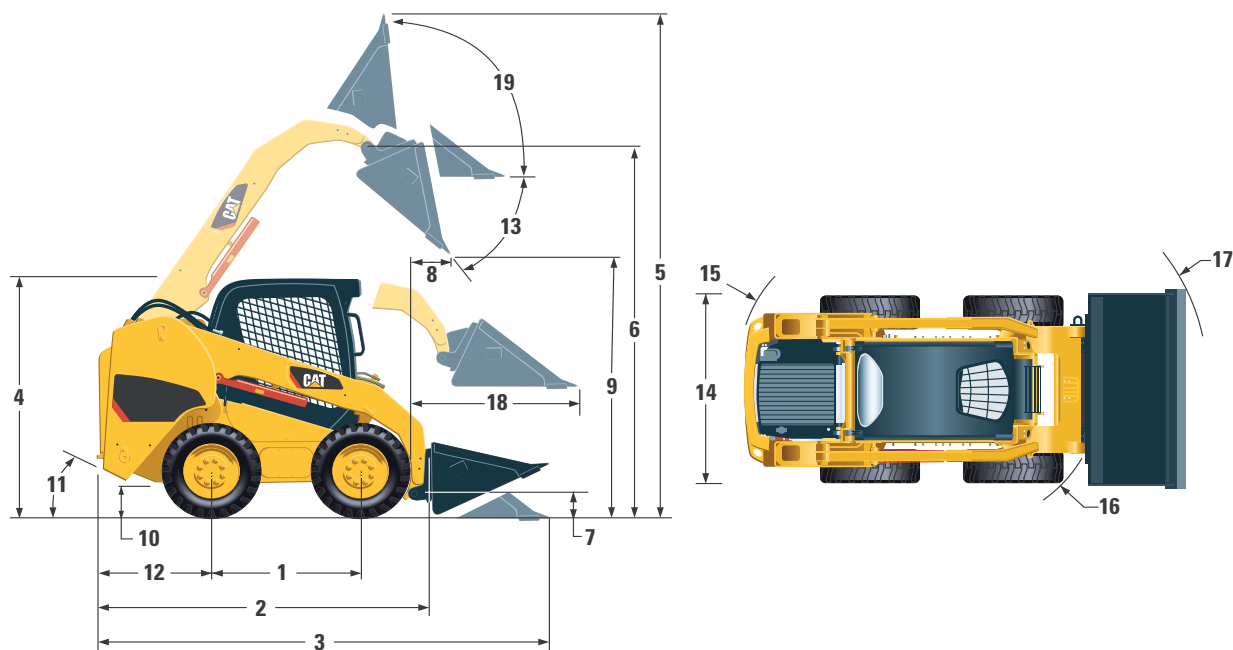

Dimensions

| | mm |
|--|------|
| 1 Wheelbase | 1240 |
| 2 Length without Bucket | 2951 |
| 3 Length with Bucket on Ground | 3692 |
| 4 Height to Top of Cab | 2083 |
| 5 Max. Overall Height | 3998 |
| 6 Bucket Pin Height at Max. Lift | 3122 |
| 7 Bucket Pin Height at Carry Position | 200 |
| 8 Reach at Max. Lift and Dump | 600 |
| 9 Clearance at Max. Lift and Dump | 2425 |
| 10 Ground Clearance | 225 |
| 11 Departure Angle | 26° |
| 12 Bumper Overhang Behind Rear Axle | 1089 |
| 13 Maximum Dump Angle | 40° |
| 14 Vehicle Width over Tires | 1676 |
| 15 Turning Radius from Center – Machine Rear | 1466 |
| 16 Turning Radius from Center – Coupler | 1650 |
| 17 Turning Radius from Center – Bucket | 2433 |
| 18 Max. Reach with Arms Parallel to Ground | 1388 |
| 19 Rack Back Angle at Max. Height | 96° |

Engine

Horsepower (hp) are metric

| | |
|--------------------------------|----------------|
| Engine Model | Cat® 3044C DIT |
| Gross Power SAE J1995 | 62 kW/84 hp |
| Net Power ISO 9249 at 2600 rpm | 61 kW/83 hp |
| Displacement | 3.3 L |
| Stroke | 120 mm |
| Bore | 94 mm |

Weight

| | |
|------------------|---------|
| Operating Weight | 3432 kg |
|------------------|---------|

Power Train

| | |
|---|---------|
| Max. Travel Speed (Forward or Reverse): | |
| One Speed | 13 km/h |
| Two Speed Option | 19 km/h |

Hydraulic System

| | |
|--------------------------------|-------------|
| Hydraulic Flow – Standard | |
| Loader Hydraulic Pressure | 230 bar |
| Loader Hydraulic Flow | 84 L/min |
| Hydraulic Power | 32 kW/43 hp |
| Hydraulic Flow – High Flow XPS | |
| Max. Loader Hydraulic Pressure | 280 bar |
| Max. Loader Hydraulic Flow | 125 L/min |

Operating Specifications

| | |
|-----------------------------|---------|
| Rated Operating Capacity | 1066 kg |
| with Optional Counterweight | 1151 kg |
| Tipping Load | 2108 kg |
| Breakout Force | 33 kN |

Cab

| | |
|------|------------------------------|
| ROPS | ISO 3471:1994 |
| FOPS | ISO 3449:1992 Level I and II |

Service Refill Capacities

| | Liter |
|----------------------|-------|
| Chain Box, each side | 10 |
| Cooling System | 14 |
| Engine Crankcase | 10 |
| Fuel Tank | 98 |
| Hydraulic System | 57 |
| Hydraulic Tank | 42 |

256C Skid Steer Loader

Work Tools

- Augers
- Angle Blades
- Brooms
- Cold Planers
- Forks & Carriages
- Grapple Buckets & Forks
- Landscape Rakes
- Landscape Tillers
- Material Handling Arms
- Stump Grinders
- Mulchers
- Trenchers
- Snow Blowers
- Vibratory Compactors
- Wheel Saws
- Dozer Blades

Standard Equipment

Electrical

- Electrical System, 12 V
- Alternator, 90 A
- Ignition Key Start/Stop Switch
- Lights: *Gauge Backlighting, Two Rear Tail Lights, Two Rear Working Lights, Two Adjustable Front Halogen Lights*
- Backup Alarm
- Heavy Duty Battery, 850 CCA

Operator Environment

- Gauges: *Fuel Level, Hour Meter*
- Operator Warning System Indicators: *Air Filter Restriction, Alternator Output, Armrest Raised/Operator Out of Seat, Engine Coolant Temperature, Engine Oil Pressure, Glow Plug Activation, Hydraulic Filter Restriction, Hydraulic Oil Temperature, Park Brake Engages*
- Vinyl Seat
- Fold in Ergonomic Contoured Armrest
- Control Interlock System, when operator leaves seat or armrest raised: *Hydraulic System Disables, Hydrostatic Transmission Disables, Parking Brake Engages*
- ROPS Cab, Open, Tilt Up
- FOPS, Level I
- Top and Rear Windows
- Headliner, Deluxe
- Floor Mat
- Interior Rear View Mirror
- 12 volt Electric Socket
- Horn

Mandatory Equipment

- Hydraulics, Standard or High Flow XPS
- Quick Coupler, Mechanical or Hydraulic
- Seat Belt, 50 mm or 75 mm
- EU Preparation Package

Comfort Package (select one of the following):

- Open ROPS (C1): *Cup Holder, Radio Ready, Suspension Seat, (no Heater or Door)*
- Enclosed ROPS with Heater (C2): *Cup Holder, Radio Ready, Seat (choice of Suspension or Air Ride), Heater and Defroster, Side Windows, Door (either Glass or Polycarbonate)*
- Enclosed ROPS with A/C (C3): *C2 and Air Conditioner*

Performance Package (select one of the following):

- Performance Package 1: *One Speed*
- Performance Package 2: *One Speed, Self Level*
- Performance Package 3: *Two Speed, Self Level*
- Performance Package 4: *Two Speed, Self Level, Ride Control, Advanced Machine Information and Control System (AMICS)*

Power Train

- Cat® 3044C DIT Stage II Compliant Diesel Engine
- Air Cleaner, Dual Element, Radial Seal
- S•O•SSM Sampling Valves, Engine Oil and Hydraulic Oil
- Filters, Spin-on, Hydraulic
- Filters, Bayonet-type, Fuel and Water Separator
- Tilt Up Radiator/Hydraulic Oil Cooler
- Spring Applied, Hydraulically Released, Wet Multi Disc Parking Brakes
- Hydrostatic Transmission
- Four Wheel Chain Drive

Other

- Engine Enclosure, Lockable
- Extended Life Antifreeze, -37°C
- Machine Tie Down Points (4)
- Support, Lift Arm
- Hydraulic Oil Level Sight Gauge
- Radiator Coolant Level Sight Gauge
- Radiator, Expansion Bottle
- Caterpillar XT™ ToughGuard™ Hose
- Auxiliary, Hydraulics, Continuous Flow
- Heavy Duty, Flat Faced Quick Disconnects
- Split D-Ring to Route Work Tool Hoses Along Side of Left Lift Arm
- Electrical Outlet, Beacon
- Belly Pan Cleanout

Optional Attachments

- Counterweight, increases rated operating capacity 90 kg
- Beacon, Rotating
- Engine Block Heater – 120 V or 240 V
- Oil, Hydraulic, Cold Operation
- Paint, Custom

256C Skid Steer Loader

For more complete information on Cat products, dealer services, and industry solutions, visit us on the web at www.cat.com

HEHX3586 (07/2007) hr

© 2007 Caterpillar -- All Rights Reserved

Materials and specifications are subject to change without notice. Featured machines in photos may include additional equipment. See your Caterpillar dealer for available options.

CAT, CATERPILLAR, their respective logos, "Caterpillar Yellow" and the POWER EDGE™ trade dress, as well as corporate and product identity used herein, are trademarks of Caterpillar and may not be used without permission.

CATERPILLAR®
TODAY'S WORK. TOMORROW'S WORLD.™